

# Smart Solar Seed Dryer Using Arduino

Amogh Jaronde

Department of Electrical Engineering,  
Shri Sant Gajanan Maharaj College of  
Engineering  
Shegaon, India  
amoghjaronde1@gmail.com

Pulkit Gaikee

Department of Electrical Engineering,  
Shri Sant Gajanan Maharaj College of  
Engineering  
Shegaon, India  
gaikeepulkit@gmail.com

Prasad Deo

Department of Electrical Engineering,  
Shri Sant Gajanan Maharaj College of  
Engineering  
Shegaon, India  
prasadd2002@gmail.com

Radhika Deshmukh

Department of Electrical Engineering,  
Shri Sant Gajanan Maharaj College of  
Engineering  
Shegaon, India  
deshmukhradhika295@gmail.com

Shubham Chhangal

Department of Electrical Engineering,  
Shri Sant Gajanan Maharaj College of  
Engineering  
Shegaon, India  
shubhamchhangal1401@gmail.com

Vaishnavi Sushir

Department of Electrical Engineering,  
Shri Sant Gajanan Maharaj College of  
Engineering  
Shegaon, India  
sushirvaishnavi002@gmail.com

**Abstract**— This research paper showcasing the formulation and evolution of an astute solar dehydrator utilizing Arduino overseer for the dehydration of agricultural goods. Utilizing solar energy as a crucial source of energy, the structure is both environmentally friendly and economically viable. An Arduino supervisor is utilized to automate the dehydration process, guaranteeing steady and ideal drying conditions. The dehydration mechanism is monitored and controlled by temperature and moisture sensors, ensuring that the products are dried to the highest possible quality. The outcomes of the scrutiny evince that the astute solar dehydrator utilizing Arduino overseer is a proficient and potent resolution for the dehydration of agricultural goods, supplying top-notch drying while reducing labour expenses and enhancing productivity. The structure presents numerous pluses over traditional dehydration methodologies, positioning it as a propitious resolution for dehydrating miscellaneous goods.

The evaporation of moisture from food grains during drying is a crucial task for farmers in storing their harvest. Drying grains is essential for long-term storage, as most harvested grains contain high moisture levels unsuitable for warehousing. India, with abundant solar resources, offers a potential solution for this process. However, traditional methods are time-consuming, require extensive space, and demand significant labor. To overcome these challenges, we propose a "solar-powered grain dryer" system that efficiently removes moisture from grains in less time, facilitating better grain storage.

**Keywords:** *Arduino UNO, solar panel, conveyor belt, and relay module.*

## I. INTRODUCTION

Drying is an essential operation in many industries, such as food processing, medicines, and agriculture, where the goal is to prolong and preserve product shelf life. Conventional drying techniques including mechanical drying, open-air drying, and sun drying have shortcomings such variable drying temperatures, poor results, and high labor costs. Therefore, in order to get over these restrictions, more sophisticated and effective drying methods are desperately needed.

An inventive and practical way to dry a variety of goods is with a smart solar dryer that uses Arduino. This system is economical and ecologically good since it uses solar energy as its main energy source. The drying process is automated by an Arduino controller, guaranteeing uniform and ideal drying conditions. Sensors for temperature and humidity are used to track and control the drying process, making sure that goods have undergone meticulous drying. Additionally, the

system has a relay module and a fan for effective and quick drying.

This study describes the planning and construction of an Arduino-powered smart solar drier that dries agricultural goods. The goal is to increase productivity and decrease labor expenses while achieving high-quality drying. The system functions reliably and economically by utilizing automation and solar electricity, which makes it a desirable option for drying a range of goods. The paper's next sections will go into further detail about the parts and workings of the system.

In India, farmers encounter numerous challenges from pre-harvesting to post-harvesting stages. One such challenge is effectively drying grains post-harvesting to safeguard them against insects, birds, and moisture re-entry. Failure to properly dry grains can lead to significant losses for farmers, regardless of storage conditions. Technological advancements have brought about significant changes in our daily lives, including the agricultural sector, where innovations continue to address various challenges. Time constraints have consistently been a significant issue for farmers, leading to numerous post-harvesting problems. The proposed solution aims to alleviate the time constraints faced by farmers after harvesting.

The following are the goals of the research report on the smart solar dryer utilizing Arduino:

to use Arduino to create a smart solar drier that can be used to dry agricultural items.

to use an Arduino controller to automate the drying process, guaranteeing uniform and ideal drying conditions.

to make economical and ecologically friendly use of solar energy as the system's main energy source.

to use temperature and humidity sensors to monitor and regulate the drying process, guaranteeing that the products are dried to a high quality.

to attain effective drying while cutting expenses on manpower and raising output.

## II. LITERATURE REVIEW

In later a long time, there has been a surge in the selection of microcontrollers like Arduino for sun oriented dryer improvement. Arduino offers a cost-effective and user-friendly stage for overseeing and overseeing the drying prepare. A ponder conducted by Srinivasan and Sangeetha (2016) exemplified this drift by utilizing Arduino in a sun oriented dryer outlined for drying mushrooms. Their setup

utilized temperature and stickiness sensors to screen the drying handle and fan for proficient drying. The discoveries illustrated that the sun based dryer essentially decreased drying of time and improved item quality is compared to conventional drying strategies. Generally, the writing survey underscores the viability of sun oriented dryers, especially those coordinates with microcontrollers such as Arduino, as a feasible and effective arrangement for drying agrarian items. These frameworks have the potential to diminish labor costs, hoist item guidelines, and contribute to natural maintainability.

### III. MATERIALS AND COMPONENTS

- Arduino UNO Board
- Solar Panel 10 Watt
- 12v Rechargeable Battery
- DHT11 Temperature and Humidity Sensor
- Hair Dryer Gun
- Voltage Regulators 7805
- Resistors
- Diodes
- LED
- Zero PCB
- 16x2 LCD
- Switches
- PB2 Connectors
- Preset 10k
- Heat Sink
- 12v male/female connectors
- Wires
- 12V Gear Motor 10RPM
- Mini Conveyer Belt
- Motor Clamps
- L293D Motor Driver Module
- 12V SPDT Relay

### IV. BLOCK DIAGRAM

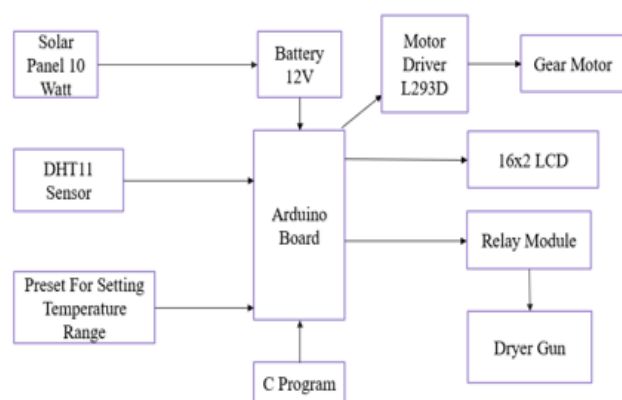

Fig. 1. Block Diagram of Smart Solar Seed Dryer Using Arduino

### V. COMPONENTS DESCRIPTION

**Solar Panel:** A solar panel comprises interconnected solar photovoltaic modules. These modules consist of packaged

assemblies of solar cells designed to harness sunlight. When integrated into larger photovoltaic systems, solar panels are employed to generate and provide power for both commercial and residential applications.

**Battery:** In contexts such as off-grid or remote areas with limited or unreliable access to the power grid, a battery plays a vital role in solar setups, especially in solar dryers. It functions as a storage device for the energy produce by solar panel during day-light hours. This stored energy can then be utilize to power the dryer during period of reduced sunlight or at night.

**Zero PCB:** Trendy reason Zero PCB. As its name indicates, widespread cause PCBs are extensively used to embed circuits randomly for running hardware. Its layer is lined with copper and lets in proper soldering with nonbriefed circuit.

**Resistors:** The resistors, a passive electrical components, introduces electrical resistance within a circuit. This resistance serves to reduce the flow of current and, simultaneously, can lower voltage levels within circuits.

**Voltage Regulators:** In circuits where voltage fluctuations occur, like those powered by sources such as the 7805, maintaining a consistent output becomes crucial. Voltage regulators, typically integrated circuits (ICs), are employed to ensure a stable and uniform output voltage.

**DHT11 Sensor:** The DHT11 Temperature & Humidity Sensors is equipped with a calibrate digital output for both temperature and humidity readings. Powered by a high-performance eight-bit microcontroller, it guarantees high reliability and long-term stability.

**Specifications:-**

Supply-Voltage: +5 V

Temperature Range: 0-60 °C with an error of  $\pm 2$  °C

Humidity: 20-90% RH with errors of  $\pm 5$  % RH

Interface: Digital

**12V SPDT Relay:** Relays serve as straightforward switches, operated either electrically or automatically. Comprising an electromagnet and a set of contacts, relays utilize the electromagnetic force for switching. Various operating principles exist, tailored to specific applications, making relays widely applicable in many devices.

**DC gear Motor:** A equipment motor is a selected kind of electrical motor this is designed to supply excessive torque even as maintaining a low horsepower, or low pace, motor output. equipment motors can be found in lots of exceptional packages and are probably used in many devices in your own home.

**L293D Motor Driver:** The L293D serves as a dual H bridge motor control integrate circuit (IC). Acting akin to current amplifiers, motor drivers receive low current control signals and output higher current signals, which are utilized to power motors.

16x2 LCD: An electronic display module widely employed in various applications is the 16x2 LCD screen, utilizing liquid crystal display technology. This module, with its straightforward design, finds extensive use in numerous devices and circuits.

The Arduino UNO, built around the ATmega328 microcontroller, stands as a versatile microcontroller board. It incorporates 14 digital input/output pins (with 6 offering PWM capabilities), 6 analog inputs, a 16 MHz crystal oscillator, a USB connection, a power jack, an ICSP header, and a reset button. With all necessary components to support the microcontroller onboard, users can effortlessly connect it to a computer via USB or other interfaces for power; alternatively, they can utilize an AC-to-DC adapter or a battery. Unlike its forerunners, the Uno doesn't rely on the FTDI USB-to-serial driver chip; instead, it utilizes the Atmega8U2 programmed as a USB-to-serial converter.

The designation "Uno," meaning "one" in Italian, symbolizes the impending release of Arduino 1.0. Positioned alongside version 1.0, the Uno is slated to become the standard iteration of Arduino moving forward. Serving as the latest addition to the USB Arduino board series, the Uno stands as the reference model for the Arduino platform.

Microcontroller Specifications:

- Model: ATmega328
- Operating Voltage: 5V
- Input Voltage Range: 7-12V
- Input Voltage Limits: 6-20V
- Digital Input/Output Pins: 14 (6 with Pulse Width Modulation capability)
- Analog Input Pins: 6
- Clock Speed: 16 MHz

## VI. WORKING METHODOLOGY

The intelligent solar drying system, incorporating an Arduino microcontroller setup, consists of various elements working together to provide an effective and eco-friendly method for drying agricultural products. Here's how the system functions:

**Solar Panels:** These panels capture sunlight and convert it into electrical energy. This harvested energy powers the Arduino controller, LCD display, relay, and the motor for tools.

**Batteries:** These units store the electrical energy generated by the solar panels. They act as a backup power source for the system during periods when there is insufficient sunlight.

**Relay:** This device controls the operation of the drying mechanism. Connected to the Arduino controller, it switches the drying mechanism on and off based on predefined drying parameters.

**Arduino Controller:** Acting as the central processing unit, the Arduino controller is the brain of the system. It oversees the drying process by monitoring temperature and humidity levels inside the drying chamber. Programmed to adjust the fan and air pump, it ensures ideal drying conditions are maintained.

In summary, the smart solar drying system utilizing Arduino technology provides an efficient and sustainable solution for drying agricultural products. By harnessing solar power and employing automation through the Arduino controller, the system proves to be both cost-effective and environmentally friendly while also being easy to use.

Software Requirement is Arduino IDE and hardware necessities are Arduino Microcontroller, solar panel, temperature sensor, heating detail, fan, battery and digicam.

The block diagram of the seed's dryer the use of sun device unit. Right here the Arduino Microcontroller is the heart of the machine. in this machine we use solar panels to supply the energy deliver to the machine. Throughout the daylight hours it observes the light power and converts it into electric electricity. The generated power is given to the charge controller and the price controller regulates the voltage and further supply flows to a battery. The battery is hooked up to the switch for the cause of controlling. here the Arduino controller makes use of 5V DC deliver and the battery voltage is 12V. To lessen the voltage from 12V to 5V we use Voltage regulator. right here we use temperature sensors, one for tracking the chamber warmth. The solar heater is used for heating the air with the aid of the convection technique of heat switch for drying the seeds. The temperature sensor senses the existing warmth in heating chamber, for maintaining temperature within the heating chamber the variety of temperature that is allowable to run best from exhaust enthusiasts are designed. when the temperature is out of the variety detected by using sensor gun is going off.

The conveyor belt, driven by a DC motor operating at a very low RPM of less than 10, facilitates the movement of grains through the dryer system. The core microcontroller utilized in the dryer setup is the Arduino. Key components of the dryer include the temperature and humidity sensor (DHT11) for monitoring grain conditions, a heating coil to warm the grains, DC fans to direct hot air onto the conveyor belts, and an L298N H bridge motor driver circuit to regulate the speed of the DC geared motors.

The temperature sensor is a detachable unit, allowing for pre- and post-drying temperature and humidity assessments of the grains. Maintaining a range of allowable temperatures for the grains, typically between 35°C to 45°C, ensures optimal drying conditions. The fans are programmed to operate efficiently within this temperature range, facilitating the efficient distribution of hot air onto the conveyor belts.

Following the drying process, the moisture content of the grains typically decreases to around 12-14%, rendering them suitable for storage.

## VII. FINAL IMPLEMENTATION



Fig. 2. Hardware model of Smart Solar Seed Dryer using Arduino



Fig. 3. Hardware model of Smart Solar Seed Dryer using Arduino

## VIII. CONCLUSION

The research paper showcases a method for efficiently drying harvested grains without delay. This technique can be completed within a few hours, offering a significant time-saving benefit for farmers. The proposed system is designed to be portable and user-friendly, requiring minimal expertise for operation as it functions automatically. Moreover, the initial and ongoing costs of the proposed system are minimal, as it utilizes cost-effective components readily accessible in the market. This model provides a valuable insight into how such a system could be implemented on a larger scale with relative accuracy.

## REFERENCES

- [1] M. M. Aziz, M. S. Sarker, M. S. Islam, M. S. Islam, and M. M. Rahman, "Solar dryer for small-scale farmers," *J. Renew. Energy*, vol. 2014, pp. 1–6, 2014.
- [2] R. K. Dhiman, S. S. Dhiman, and S. Singh, "Performance evaluation of solar tunnel dryer for drying chilies," *J. Renew. Energy*, vol. 2014, pp. 1–6, 2014.
- [3] T. H. Kim, K. R. Lee, and J. H. Kim, "Development of an automated solar dryer for marine products," *Energies*, vol. 8, no. 7, pp. 6850–6865, 2015.
- [4] A. M. Issa, A. S. Farghally, and H. A. Algebaly, "Design and simulation of solar dryer for pomegranate arils," *J. Saudi Soc. Agric. Sci.*, vol. 16, no. 4, pp. 350–358, 2017.
- [5] T. M. Njoroge, E. N. Gachanja, and J. W. Gichimu, "Performance evaluation of a solar tunnel dryer for drying sweet potato chips," *Int. J. Renew. Energy Res.*, vol. 3, no. 3, pp. 548–553, 2013.
- [6] M. O. Omojola and S. O. Oyedepo, "Design and construction of a solar dryer for fruit and vegetable preservation," *J. Agric. Sci. Environ. Technol.*, vol. 1, no. 1, pp. 28–34, 2015.
- [7] D. D. Olatunde, O. A. Adedoyin, and O. O. Adegunloye, "Design and construction of a solar dryer for mango slices," *Int. J. Energy Eng.*, vol. 3, no. 1, pp. 13–19, 2013.